

**HOUSING FOR STRAIGHT PLUG**

**R197.112.B90**

Series : **SMB**  
**CARLOCK**

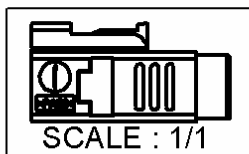
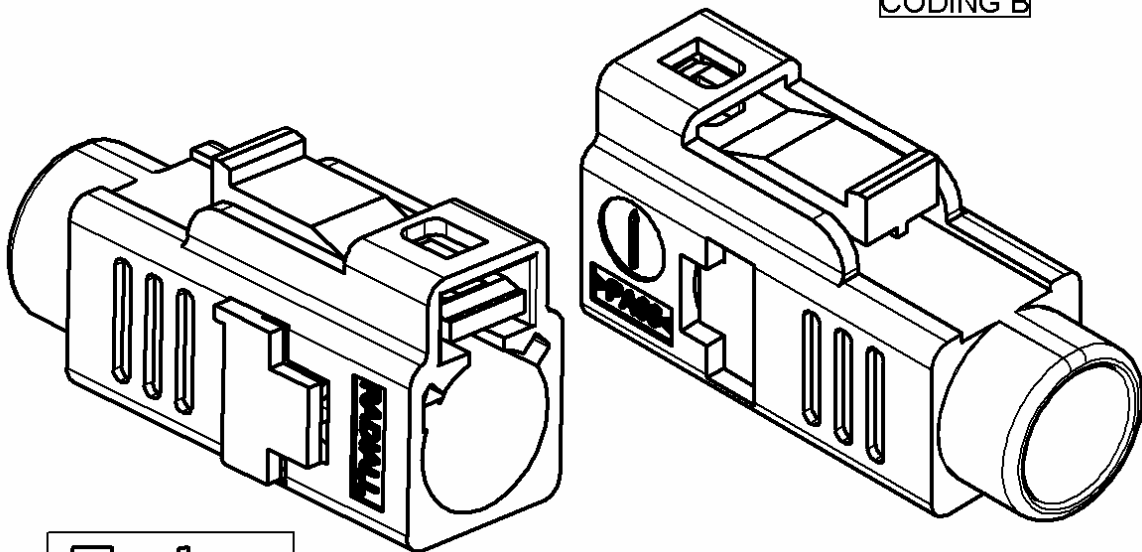
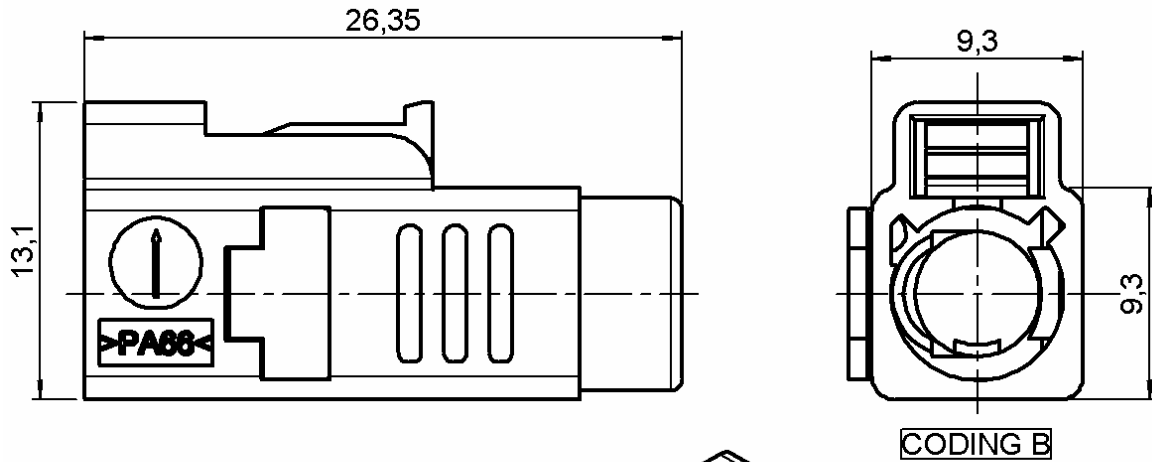

All dimensions are in mm.

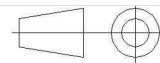

COMPONENTS		MATERIALS	PLATINGS (µm)	
HOUSING SECONDARY LOCK	PA66 PA66		UL CLASSIFICATION	COLOR
			UL 94 V-2 UL 94 V-2	WHITE Ral9003 PURPLE Ral4006
*According to FAKRA specifications				

Issue : 0334 A

In the effort to improve our products, we reserve the right to make changes judged to be necessary.



**HOUSING FOR STRAIGHT PLUG**

**R197.112.B90**

Series : **SMB**  
**CARLOCK**

**PACKAGING**

**SPECIFICATION**

Standard	Unit	Other
<b>100</b>	<b>'W' option</b>	<b>Contact us</b>

**QS9000**

**ELECTRICAL CHARACTERISTICS**

**ENVIRONMENTAL**

Impedance  $\Omega$   
 Frequency GHz  
 VSWR + **0.000** x F(GHz) Maxi  
 Insertion loss  $\sqrt{F(\text{GHz})}$  dB Maxi  
 RF leakage - ( - F(GHz)) dB Maxi  
 Voltage rating Veff Maxi  
 Dielectric withstanding voltage Veff mini  
 Insulation resistance M $\Omega$  mini

Operating temperature **-40/+110** ° C  
 Hermetic seal Atm.cm3/s  
 Panel leakage

**OTHERS CHARACTERISTICS**

Assembly instruction **Page 3 & 4**

Others :

**HOUSING FOR COAX**  
**R114.082.325,R114.086.325,R114.089.325**

**MECHANICAL CHARACTERISTICS**

Center contact retention  
 Axial force – Mating end N mini  
 Axial force – Opposite end N mini  
 Torque N.cm mini

Recommended torque  
 Mating N.cm  
 Panel nut N.cm

Mating life **100** Cycles mini  
 Weight **1.736** g

**Issue : 0334 A**

In the effort to improve our products, we reserve the right to make changes judged to be necessary.



## HOUSING FOR STRAIGHT PLUG

**R197.112.B90**Series : SMB  
CARLOCK***RECOMMENDED MOUNTING PROCEDURE***

1

- Push the coax until it stops at the bottom of the housing

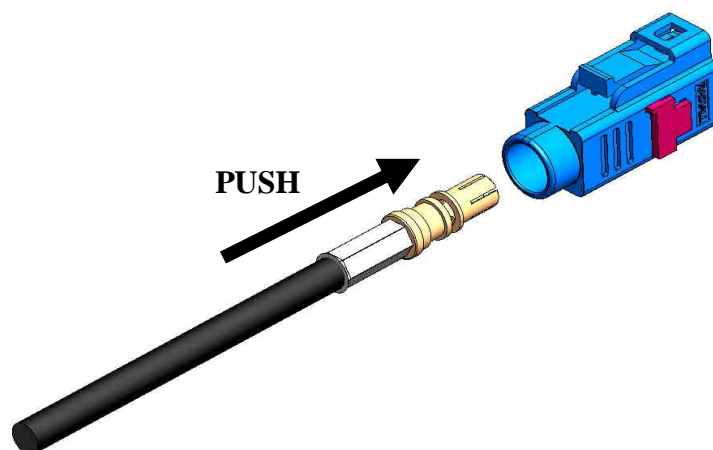

2

- Push the secondary lock in final position to secure the coax inside the housing (until it click on)

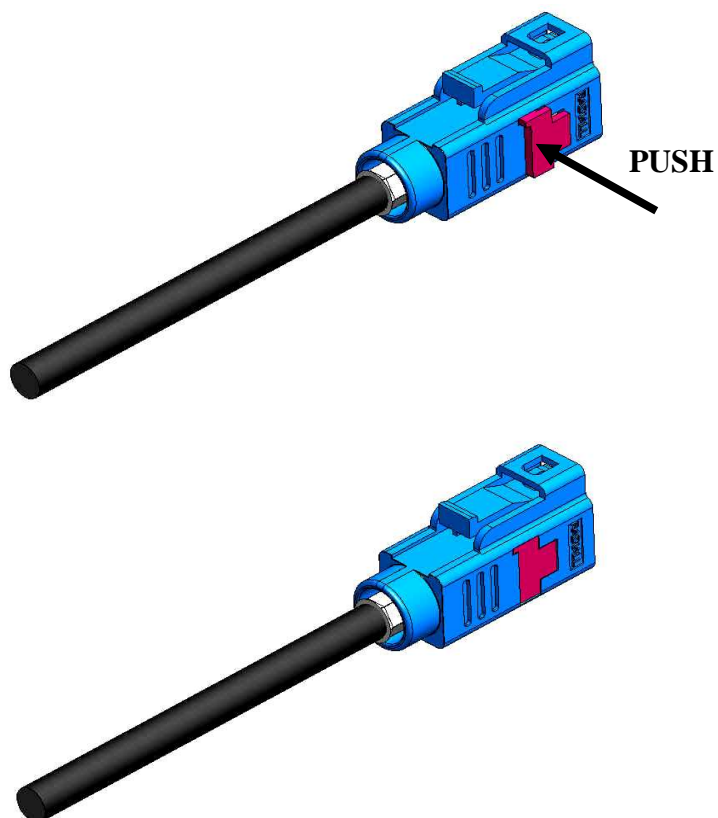

Issue : 0334 A

In the effort to improve our products, we reserve the right to make changes judged to be necessary.

## HOUSING FOR STRAIGHT PLUG

**R197.112.B90**Series : SMB  
CARLOCK**RECOMMENDED DISASSEMBLING PROCEDURE**

1

- To unlock the coax from the CPA devise, push the secondary lock from the material marking side until it click on

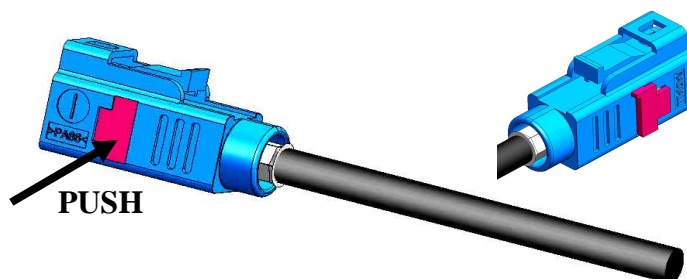

2

- insert a screw driver between the elastic finger and the slot of the housing as shown on the picture.
- Tip up the screw driver as shown on the picture to lift up the elastic finger and when it is done pull on the cable assembly to remove the coax from the housing.

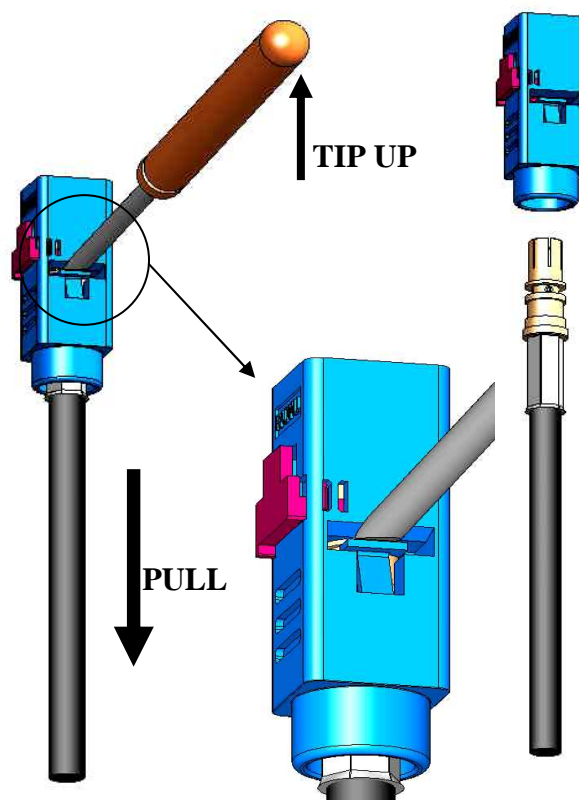

Issue : 0334 A

In the effort to improve our products, we reserve the right to make changes judged to be necessary.

**RADIALL**®